



TecnoBrick[®]
by  **TecnolIndustries**[®]

BRICK
Brochure



SMOOTH FACE

Provides a conventional smooth finish that creates a timeless and classic look for any exterior.

Available Sizes: Executive and King

(King Dimensions)

(Executive Dimensions)

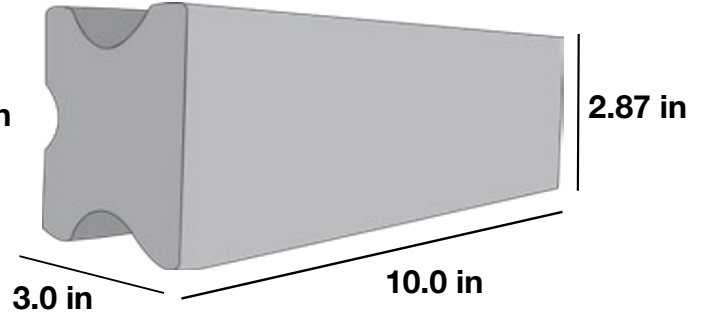
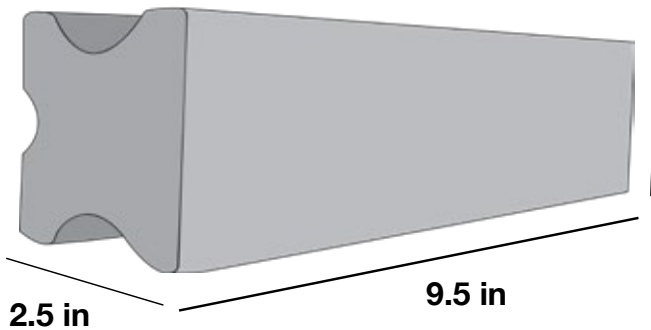

Benefits

- * Color can be modified and customized to fit any project's design
- * Shape, joints and color guaranteed to withstand any weather conditions and UV light
- * Manufactured with the elegance, sparkle and durability of marble

Technical Information (ASTM C55-16)

King Size (200 Series)

Pallet: 488 units
Pallet Coverage: 96.21 ft²
Units per Ft²: 5.1 units/ft²
Unit Weight: 4.85 lbs/unit
PSI Value per Unit: 2,000 PSI
Absorption per Unit: < 15%

Executive Size (400 Series)

Pallet: 448 units
Pallet Coverage: 108.94 ft²
Units per Ft²: 4.1 units/ft²
Unit Weight: 6.00 lbs/unit
PSI Value per Unit: 2,000 PSI
Absorption per Unit: < 15%

SMOOTH FACE BRICK



Main Line Colors *(Palette Colors Shown in Executive Size)*



Artic White Plain
201, 401



White Midst Antique
281-A, 481-A



Charcoal Gray Antique
222-A, 422-A

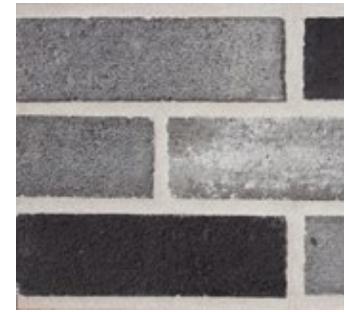

**Peppered Limestone
Antique**
221-AN, 421-AN



Dark Antique
291-DA, 491-DA



Cambridge
242-D, 442-D



Chestnut
277-AC, 477-AC



Executive Cypress
277-P, 477-P



El Dorado
216-PV, 416-PV



Peppered Limestone
221-N, 421-N

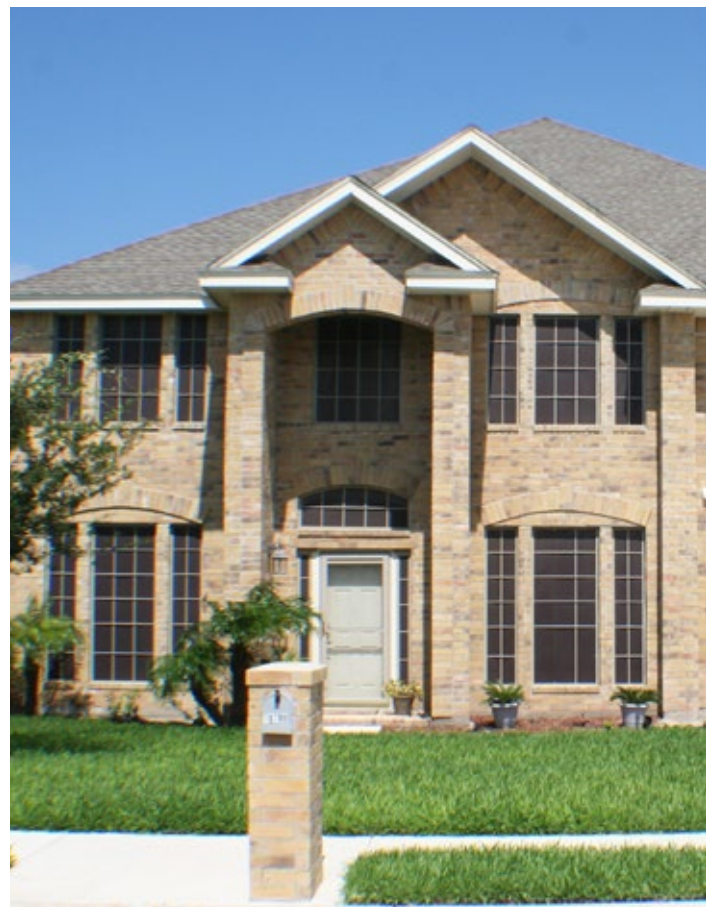

415-A, Sonora

*Visit our website to see our complete
Smooth Face color palette.*

SMOOTH FACE BRICK



Special Order Colors (*Palette Colors Shown in Executive Size*)



Walton
232, 432



Dessert Tan
277-DT, 477-DT



Prescott
249, 449



Dark
291-D, 491-D



Dermott
296-CA, 496-CA



**Peppered
Antique**
291-PA, 491-PA



Elmswood
225, 425



Cimarron
252-C, 452-C



419-T, *Executive Antigua*

SMOOTH FACE BRICK



413-AB, Old Town



442-D, Cambridge

SMOOTH FACE BRICK



477-P, Executive Cypress



452-D, Merlot



ROCK FACE

*Clean lines and a solid rough face
great for any exterior in need of a unique design.*

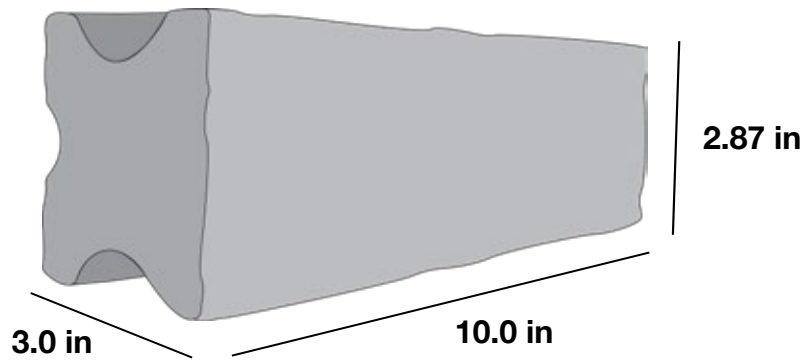

Benefits

- * Color can be modified and customized to fit any project's design
- * Shape, joints and color guaranteed to withstand any weather conditions and UV light
- * Manufactured with the elegance, sparkle and durability of marble

Technical Information (ASTM C55-16)

Pallet: 448 units

Pallet Coverage: 108.94 ft²

Units per Ft²: 4.1 units/ft²

Unit Weight: 6.97 lbs/unit

PSI Value per Unit: 2,000 PSI

Absorption per Unit: < 15%

ROCK FACE BRICK

Main Line Colors



Arctic White
501-R



Light Buff
561-R



Slate Gray
521-R

Special Order Colors



Fuego
541-R



Chocolate
551-R



Walnut Brown
531-R



Sand Stone
571-R



541- R, Fuego



Pewter
581-R



Steel Gray
591-DR



Ivory
591-R



Arctic White Tumbled
501-RT

ROCK FACE BRICK



*531- R,
Walnut Brown*



*561- R,
Light Buff*



*591- R,
Ivory*

VINTAGE ANTIQUE

Provides beauty and a rustic feel for all homes, buildings and construction projects.

Available Sizes: King and Modular

(King Dimensions)

(Modular Dimensions)

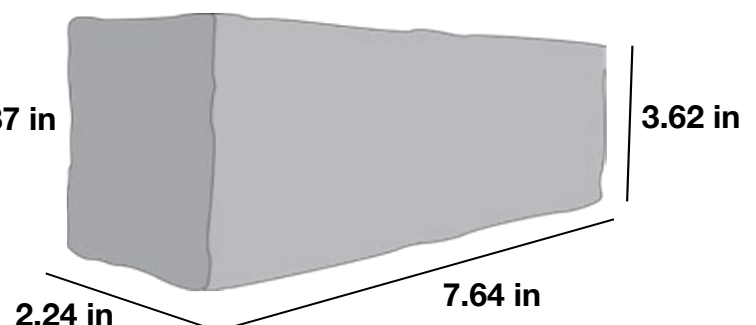
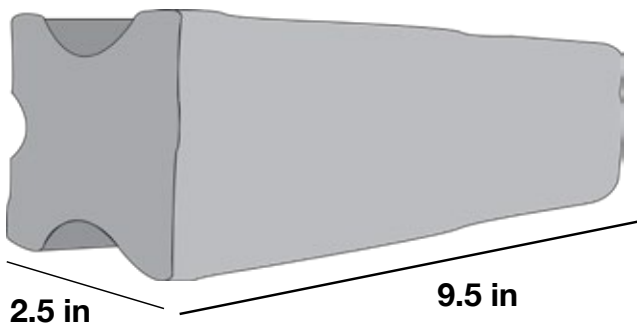

Benefits

- * Color can be modified and customized to fit any project's design
- * Shape, joints and color guaranteed to withstand any weather conditions and UV light
- * Manufactured with the elegance, sparkle and durability of marble

Technical Information (ASTM C55-16)

King Size (200 Series)

Pallet: 488 units
Pallet Coverage: 96.21 ft²
Units per Ft²: 5.1 units/ft²
Unit Weight: 4.85 lbs/unit
PSI Value per Unit: 2,000 PSI
Absorption per Unit: < 15%

Modular Size (300 Series)

Pallet: 480 units
Pallet Coverage: 69.86 ft²
Units per Ft²: 6.9 units/ft²
Unit Weight: 4.85 lbs/unit
PSI Value per Unit: 2,000 PSI
Absorption per Unit: < 15%

VINTAGE ANTIQUE BRICK



Main Line Colors



New Orleans
213P-T, 313P-T



Waterloo
221-AT, 321-AT



San Marcos
235-AT, 335-AT



Vintage Tacoma
273-AT, 373-AT

Special Order Colors



Old Amherst
268P-T, 368P-T



Vintage Sedona
251P-T, 351P-T



Santa Fe
263-AT, 363-AT



**Vintage Old
San Luis**
2617-A, 3617-A



313P-T, New Orleans



313P-T, New Orleans



313P-T, New Orleans

TUMBLE STONE

Offers a unique shape guaranteed to make any exterior one of a kind. Corners available.

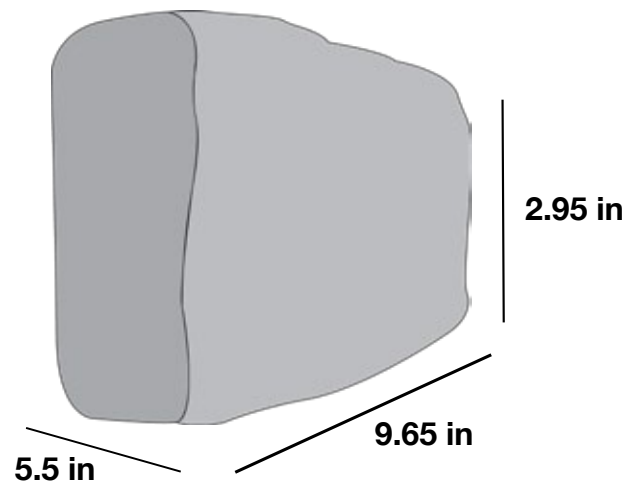

Benefits

- * Color can be modified and customized to fit any project's design
- * Shape, joints and color guaranteed to withstand any weather conditions and UV light
- * Manufactured with the elegance, sparkle and durability of marble

Technical Information (ASTM C55-16)

Pallet: 244 units

Pallet Coverage: 99.8 ft²

Units per Ft²: 2.4 units/ft²

Unit Weight: 12.17 lbs/unit

PSI Value per Unit: 2,000 PSI

Absorption per Unit: < 15%

TUMBLE STONE BRICK



Main Line Colors

Special Order Colors



**White Stone
Tumbling**
1001-RT

**Lite Buff Stone
Tumbling**
1061-RT

**Adobe Stone
Tumbling**
1013-RT

**White Desert
Stone Tumbling**
1091-RT



1001-RT, White Stone Tumbling

TUMBLE STONE BRICK



*1013-RT,
Adobe Stone
Tumbling*



*1061-RT,
Light Buff Stone
Tumbling*



*1001-RT,
White Stone
Tumbling*

SPLIT FACE

A slightly beveled combination of a smooth and rough face, sure to stand out from all the rest.

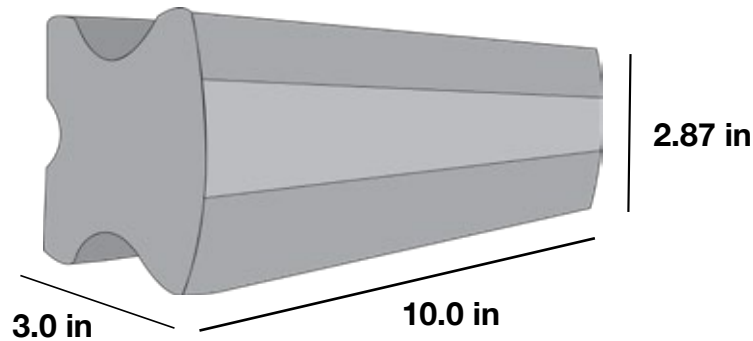

Benefits

- * Color can be modified and customized to fit any project's design
- * Shape, joints and color guaranteed to withstand any weather conditions and UV light
- * Manufactured with the elegance, sparkle and durability of marble

Technical Information (ASTM C55-16)

Pallet: 408 units

Pallet Coverage: 99.21 ft²

Units per Ft²: 4.1 units/ft²

Unit Weight: 7.606 lbs/unit

PSI Value per Unit: 2,000 PSI

Absorption per Unit: < 15%

SPLIT FACE BRICK



Special Order Colors



Artic White
101



Coral
110



Buff
161



Sand Stone
171



161, Buff



110, Coral

THIN BRICK

Provides the same look as the Rock Face Brick with one third of the weight and thickness.

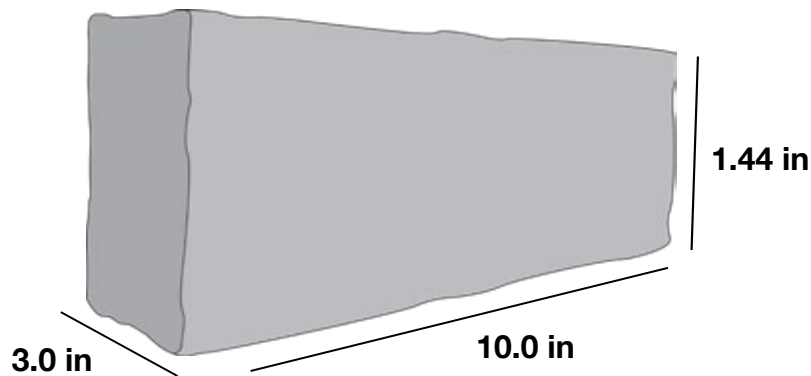

Benefits

- * Color can be modified and customized to fit any project's design
- * Shape, joints and color guaranteed to withstand any weather conditions and UV light
- * Manufactured with the elegance, sparkle and durability of marble

Technical Information (ASTM C55-16)

Pallet: 880 units

Pallet Coverage: 213.98 ft²

Units per Ft²: 4.1 units/ft²

Unit Weight: 3.00 lbs/unit

PSI Value per Unit: 2,000 PSI

Absorption per Unit: < 15%

THIN BRICK

Main Line Colors



Arctic White
F501-R



Light Buff
F561-R



Slate Gray
F521-R

Special Order Colors



Ivory
F591-R



Pewter
F581-R



Steel Gray
F591-DR



Sand Stone
F571-R



**Arctic White
Tumbled** *F501-RT*



Fuego
F541-R



Chocolate
F551-R



Walnut Brown
F531-R

THIN BRICK



*F531- R,
Walnut Brown*



*F561- R,
Light Buff*

ROCK FACE BLOCK

(6" Block)

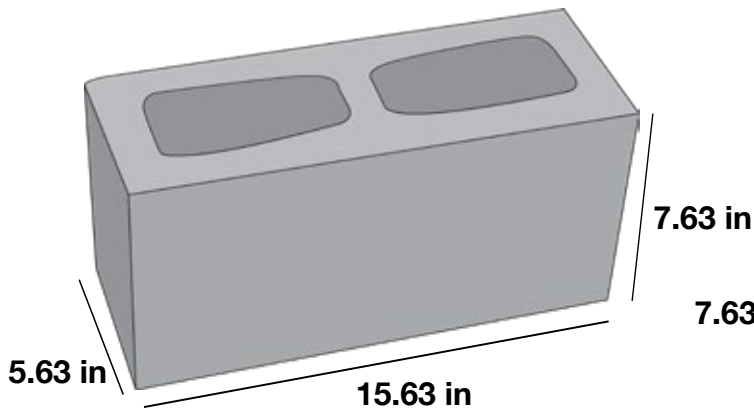

(8" Block)

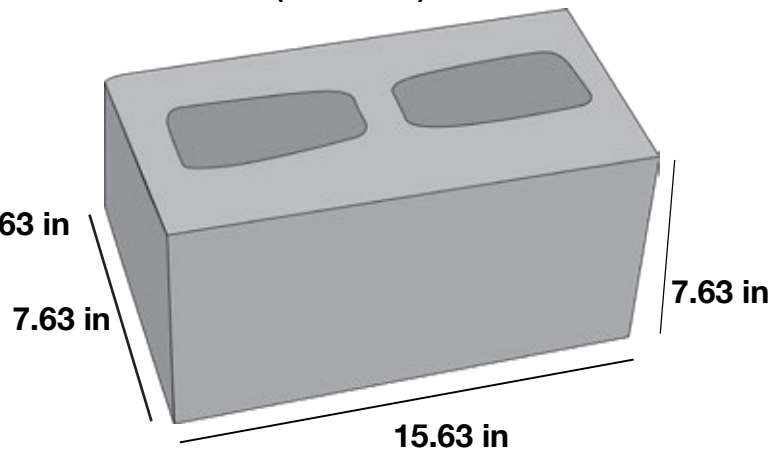

Benefits

- * Walls, retention walls and decorative coatings
- * Color can be modified and customized to fit any project's design
- * Shape, joints and color guaranteed to withstand any weather conditions and UV light

Technical Information (ASTM C90-16)

6" Block (B-600-R Series)

Pallet: 90 units

Pallet Coverage: 80 ft²

Units per ft²: 1.1 units/ft²

Compressive Strength/Unit: 1,700 PSI

Unit Weight: 36.07 lbs/unit

Absorption per Unit: < 9%

Net Area: 87.99 in²

Gross Area: 50.75 in²

8" Block (B-800-R Series)

Pallet: 72 units

Pallet Coverage: 72 ft²

Units per ft²: 1.1 units/ft²

Compressive Strength/Unit: 1,700 PSI

Unit Weight: 45.37 lbs/unit

Absorption per Unit: < 9%

Net Area: 119.12 in²

Gross Area: 62.72 in²

Available Colors

