



TecnoBrick[®]
by  **TecnolIndustries**[®]

SQUARE
Brochure

Alfa Planetarium, MX





SQUARE

Creates a modern and fresh look fit for all your landscaping ambitions

Benefits

- * Color can be modified and customized to fit any project's design
- * Shape, joints and color guaranteed to withstand heavy use, any weather conditions and UV light
- * Suitable for any setting: patios, sidewalks and parks

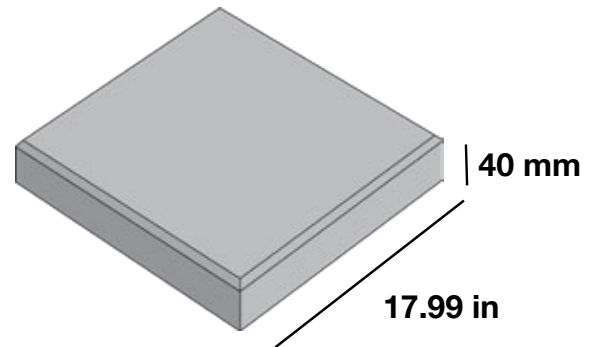

Technical Information

Pallet: 48 units

Pallet Coverage: 107.85 ft²

Units per ft²: 0.44 units/ft²

Unit Weight: 38.58 lbs/unit

Compressive Strength: 3,000 psi

Absorption: < 9%

Application: Pedestrian Use

Available Colors



01

81

91-AB

66

71-CL

71

31

62

80



51

41

00-V

91-L

21

91

91-D



Alfa Planetarium, MX

